TACT

TA-4800

**MAN ALONE PERSONAL SAFETY ALARM
RADIO / TELEPHONE INTERCONNECT**

RACK MOUNT VERSION

USER HANDBOOK

Issue 2, Dec, 2009

ACMA SUPPLIER'S CODE N468

NEW ZEALAND TELEPERMIT PTC 210/96/003

DESIGNED AND MANUFACTURED IN AUSTRALIA

design2000

DESIGN TWO THOUSAND PTY LTD

DESIGN TWO THOUSAND IS CERTIFIED TO AS3901/ISO9001/NZS9001

MADE IN AUSTRALIA

TACT TA-4800

TACT TA-4800 MAN ALONE PERSONAL SAFETY ALARM SYSTEM

TWO WAY RADIO/TELEPHONE INTERCONNECT

19" RACK MOUNT VERSION

Operator Manual - Document Number G/00123C

CONTENTS	PAGE
INTRODUCTION	1
Features	1
TACT Indicators and connectors	2
USING TACT	
Watchdog on/off	4
Watchdog timer	4
Response timer	4
Duress Alarm	4
Functional Description	5
Alarm dial numbers	6
SYSTEM CONFIGURATION	
System configuration codes	7
EPROM version number	10
CONNECTION DIAGRAM	11
Connections	12
Audio level adjustments	14
Audio output to the radio (Tx)	14
Audio input from the radio (Rx)	14
COS and PTT connection	15
SUMMARIES	
Summary of user codes	16



Est. 1968

www.design2000.com.au

DESIGN TWO THOUSAND PTY LTD

TACT TA-4800 MAN ALONE PERSONAL SAFETY ALARM - RADIO/TELEPHONE INTERCONNECT

INTRODUCTION

TACT, the Telephone Access Control Terminal, interconnects a two-way radio system to a telephone line or PABX extension.

In this application, TACT forms part of a portable emergency alarm system for a lone worker. It acts as an independent watchdog that monitors the worker's safety and reports any incidents to central station(s). Incident reports can include that a worker has failed to respond when he or she was requested to or that a 'duress' alarm has occurred.

Design Two Thousand Pty Ltd, established in 1968, has been making TACT units since 1987, and this TA-4800 is the new flagship model. It is the digital successor to the well-proven TA-7.

FEATURES

- Watchdog on/off control.
- Safety check. Verbally requests the worker to respond by pressing the PTT button if they are OK.
- Sends a second (reminder) request to respond if a response is not received the first time.
- Calls up the operations centre(s) and reports if the worker has failed to respond.
- Duress alarm. Calls up the operations centre(s) and reports if a duress alarm has been triggered by the PTT button being pressed outside of the call request times.
- Dialing in the event of any alarm incident continues until an acknowledgement [5] is received from the operations centre.
- Programmable Watchdog timer (0-255 mins).
- Programmable Response timer (0-255 secs).
- Up to four programmable alarm dial numbers.
- Digital voice requests and responses.
- DTMF signaling for acknowledgements.
- Local and Remote programming
- Alarm input
- DTMF dialing
- Dial tone detect
- Exchange (CO) or PABX line
- Busy tone detect
- Line reversal detect
- Call progress display
- Programmable level adjustments
- Simplex / half duplex/ duplex
- EPROM version number display
- RS232 port for PC control, programming, status messages, and diagnostics
- RS232 ports for modem & telemetry Interface
- 12 → 48 Vdc working. (Polarity and ground insensitive)
- 1 RU, 19" rack mountable enclosure
- Two Year warranty
- ACA Supplier's Code N468

LOCAL PROGRAMMING

All user programmed data and system options can be verified or changed from the inbuilt keypad.

Data retained in memory can also be interrogated and altered at higher speed using a PC.

User functions are easily selected by pressing the appropriate number keys. Access to reading or changing system options requires access codes as detailed later in this handbook.

PROGRAMMING PROCEDURES

There are two programming levels that can be accessed:

1. Turning the Watchdog on or off.
2. System timers.

1. From The Keypad

Simply press the required number keys as detailed in this handbook. Confirmation is displayed to the user on the LED monitor.

TACT INDICATORS

Programming progress and success is displayed on the seven segment LED monitor display. (Remote operation is prompted and confirmed by the voice synthesizer). The 7 segment monitor display also provides call progress information:

- 0 = silence
- 1 = busy tone
- 2 = modulated dial tone
- 3 = N.U. tone
- 4 = speech
- 5 = continuous tone
- 6 = indeterminate tone
- 7 = ringing tone
- 8 = unmodulated ringing tone.
- 9 = random disconnect tone
- n. = DTMF

In addition to the monitor display, visual indication of operating progress is provided by six LEDs on the front panel marked 'POWER', 'READY', 'CONNECT', 'ON AIR' 'Tx', and 'Rx'.

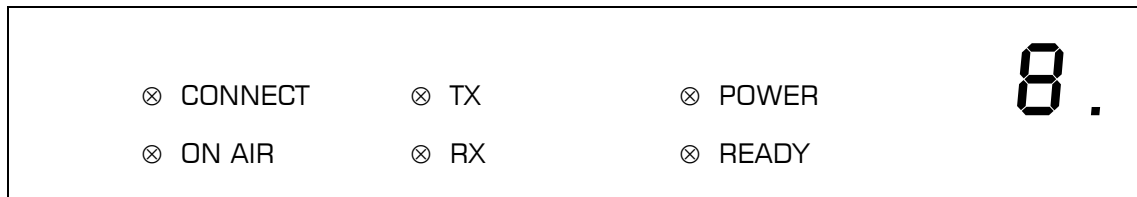

The 'POWER' LED indicates that power is connected and that the internal fuse is intact. The 'READY' LED indicates that the system is ready and that the Watchdog is functioning. The 'CONNECT' LED illuminates whenever the PSTN telephone line (L1) is seized. The 'ON AIR' LED illuminates whenever an alarm incident is being reported but the operations centre has not yet acknowledged. The Tx and Rx LEDs indicate transmit (PTT) and receive (COS) from the radio.

TACT CONNECTORS

12→ 48V power input:	BL-2 plug
Telephone line:	RJ 12
Second telephone line:	RJ 12 (Not used for this application)
Radio:	RJ 45
RS232 Port	RJ 45 (Call Data /Diagnostics)

Please refer to 'CONNECTIONS' for connector details.

TURNING THE WATCHDOG ON OR OFF

The TACT Watchdog mode checks the worker's safety.

On

1. Press 123 on the TACT keypad.
2. The 'Ready' Light will come on and TACT begins the "Please Respond" Watchdog cycle.

Off

1. Press 321 on the TACT keypad.
2. The 'Ready' light will go out and the Watchdog cycle is disabled. The Duress alarm and Alarm input however remain active.

WATCHDOG TIMER

A Man Alone safety check is performed each time a special timer called the Watchdog Timer expires.

The Watchdog timer can be adjusted from 0 to 255 minutes. The factory preset time is 60 minutes ie. every 60 minutes the TACT will call for a response from the Lone Worker.

To Adjust the Watchdog timer:

1. Press *6703#
2. Press * 90 mmm, where mmm is the time in minutes (000-255).
3. Press *#.

RESPONSE & REMINDER TIMER

After TACT has called for a response, a response timer can be set to give the Lone Worker time to respond. The Response timer and (second) Reminder timer can be adjusted from 0 to 255 seconds. The factory preset time is 60 seconds ie. the Lone Worker has a total of two minutes to respond and confirm that they are OK.

1. Press *6703#
2. Press * 91 sss, where sss is the time in seconds (000-255).
3. Press *#.

Note:	On a simplex radio system, the Lone Worker must respond by pressing the PTT button after the voice request has finished and not during the voice request.
-------	-----------------------------------------------------------------------------------------------------------------------------------------------------------

DURESS ALARM

1. At anytime outside the 'Safety Check' times, the Lone Worker can signal a Duress condition by pressing the PTT button on their portable radio.
2. TACT announces "*The Duress alarm is armed, press the PTT button again if you want to cancel the alarm*" to the radio.
3. If the Lone Worker presses the PTT button within the Reminder Timer, they will hear "*Duress alarm cancelled*" and no alarm will be reported.
4. If the Lone Worker does not press the PTT button within the Reminder Timer, they will hear "*The duty operator at 'XYZ' is under duress. Send help*" and TACT commences to dial the alarm numbers to report the incident.

FUNCTIONAL DESCRIPTION

TACT ON/OFF

On

Press 123

TACT is 'ready' and active. When turned on, TACT sends Message 1 and starts Timer 2 below.

Off

Press 321

TACT is inactive but the Duress alarm (and Alarm input) remains on stand-by.

MESSAGES

1. To Radio: *"Safety check, please press your PTT button"*
2. To Radio: *"Safety check, final reminder, please press your PTT button"*
3. To Radio: *"Response acknowledged. Thank you"*
4. To Phone: *"The duty operator at this site has not responded to a safety check. Send help"* "Press 5 to acknowledge this call".
5. To Radio: *"The Duress alarm is armed, press the PTT button again if you want to cancel the alarm"*
6. To Radio: *"Duress alarm cancelled"*
7. To Phone: *"The duty operator at this site is under duress. Send help"*. "Press 5 to acknowledge this call"
8. To Phone: *"Press 5 to acknowledge this call"*

TIMERS

Timer 1

Watch Dog Timer

0 –255 minutes (default 60 minutes)

Timer 2

Response Timer and Reminder Timer

0 –255 seconds (default 60 seconds)

SAFETY CHECK WATCHDOG

- When Timer 1 expires, TACT sends message 1 and starts Timer 2.
- Reset Timer 1 and Timer 2 and send message 3 if PTT response is received.
- If Timer 2 expires, send message 2 and start timer 2 again.
- Reset Timer 1 and Timer 2 and send message 3 if PTT response is received.
- If Timer 2 expires for the second and final time, dial alarm numbers and send message 4. (DTMF 5 from phone to reset).

Note:	On a simplex radio system, the Lone Worker must respond by pressing the PTT button after the voice request has finished and not during the voice request.
-------	-----------------------------------------------------------------------------------------------------------------------------------------------------------

DURESS ALARM

- If a PTT from radio (COS to TACT) occurs outside of Timer 2, TACT sends message 5 and starts Timer 2.
- Reset Timer 2 and send message 6 if PTT response is received.
- If Timer 2 expires, dial alarm numbers and send message 7 (DTMF 5 from phone to reset).

ALARM INPUT

- If a contact closure occurs on the TACT alarm input (emergency alarm has been triggered by a radio man down switch) TACT dials the alarm numbers and sends Message 7. (Press [5] on the telephone to acknowledge and reset).

ALARM DIAL NUMBERS

TACT performs the alarm dialer function. Up to 4 different telephone numbers can be dialed in succession where the appropriate "Alarm activated" message is played to each number for sixty seconds. When you receive an alarm call, you can **press [5] to acknowledge the alarm** and stop TACT from dialing any further for that alarm.

To Enter the First Alarm Dial Number

1. Press * 81 nnnnnnnnn #, where nnnnnnnnn is the first number to be dialed.

To Enter the Second Alarm Dial Number

1. Press * 82 nnnnnnnnn #, where nnnnnnnnn is the second number to be dialed.

To Enter the Third Alarm Dial Number

1. Press * 83 nnnnnnnnn #, where nnnnnnnnn is the third number to be dialed.

To Enter the Fourth Alarm Dial Number

1. Press * 84 nnnnnnnnn #, where nnnnnnnnn is the forth number to be dialed.

To Erase a Number

1. Enter a single '0' in place of nnnnnnnnn as detailed just above.

AUXILIARY OUTPUT RELAYS

The Auxiliary Output Relays can be connected to most switchable systems. This provides for the control of sirens, security systems, power gates, electric door strikes and more. The relay(s) can also be wired back into the TACT Alarm input to force an Alarm dial.

To Operate the Relay One

1. Press * 07 1 #. Listen for "Relay one operated".

To Interrogate the Relay One State

1. Press * 07 #. Listen for "Relay one operated" or "Relay one idle".

To Reset the Relay One

1. Press * 07 0 #. Listen for "Relay one idle".

To Operate the Relay Two

1. Press * 08 1 #. Listen for "Relay two operated".

To Interrogate the Relay Two State

1. Press * 08 #. Listen for "Relay two operated" or "Relay two idle".

To Reset the Relay Two

1. Press * 08 0 #. Listen for "Relay two idle".

SYSTEM CONFIGURATION

Programming can be done from the TACT inbuilt keypad, remote telephone or radio.

The programming is the same from the keypad, remote phone or the serial port. An extra step is required when accessing programming from a phone or radio. After connection, type *6700# to enter programming mode.

1. Press *6703# to enter system configuration programming mode.
2. Press *nn, where nn is the required option number from the table below.
 - TACT then reports the selected option number and its current status.
3. Enter a new value as required.
 - TACT then reports the option number and its new status.
4. Press *# to save and exit, OR
Press # to scroll to the next option OR
Press *nn, where nn is another required option number from the table below.
5. Enter a new value as required.
 - TACT then reports the selected option number and its new status.
6. Press *# to save and exit (or press ** to abort all changes)

Command Summary

*6703#

* nn where nn is option number

n... = entry

= scroll

** = abandon

*# = store & end

OPTION CODES

PLEASE NOTE: Not all of the following options are applicable to the Man Alone application

Code	Function	Range	Default	Description
*01	Reversal On Idle Ignore Incoming telephone Calls	0,1	0	0 = enable CPC detection 1 = disable CPC detection
*02	Reversal On Idle Ignore Outgoing Calls	0,1	0	0 = enable CPC detection 1 = disable CPC detection
*03	Reversal On Answer Ignore	0,1	0	0 = enable ROA detection 1 = disable ROA detection. NOT USED.
*04	Decadic Dialing	0,1	0	0 = DTMF 1 = Decadic NOT USED
*05	Dial tone Ignore	0,1	0	0 = hang up after 4 seconds if no dial tone. 1 = Dial after 2 seconds regardless of dial tone.
*06	Delay After First Digit for 'outside' access	0,1	0	0 = no delay 1 = 2 second delay after first digit when dialing.
*07	Loop Break on silence	0,1	0	0 = no loop break 1 = momentarily hang up phone line when silence detected for 20 seconds on an incoming call. NOT IMPLEMENTED
*08	Digit Limit	0-21	21	0 = no digit limit other = max number of digits that can be dialed by TACT
*09	Hook flash Time	0-3000	0100	ms for hook flash
*10	Manual/Auto Answer	0,1	0	0 = Auto Answer 1 = Manual Answer
*11	Answer Delay	0-255	000	Seconds before auto answering a call or sending ring tone to radio.

*12	Ring Voltage Gap	0-9	5	Seconds maximum gap in ringing voltage.
*13	Absolute signal level detect (VOX minimum activate level)	0-255	080	qdB. Minimum detect threshold for phone lines. Bigger is less sensitive
*14	CTCSS encode	00-50	00	The CTCSS tone to use for this line. NOT IMPLEMENTED
*15	Silence Disconnect	0-255	002	Minutes of silence to disconnect phone line. NOT IMPLEMENTED Could be used for not TX timeout
*16	Total call time limit	0-255	060	Minutes total call time limit NOT IMPLEMENTED
*17	Continuous tone disconnect	0-255	010	Seconds of continuous tone before disconnection.
*18	Malicious call trace	1,2	1	1 = normal 2 = hook flash on incoming call. NOT IMPLEMENTED.
*19	PIN required on phone line	0,1	0	0 = normal 1 = PIN required to access radio Must not be in manual answer mode.
*20	Who Called Enabled	0,1	0	0 = normal operation 1 = invite to leave who called info NOT IMPLEMENTED
*21	Two Tone Plan	00-20	16 (S)	Motorola two tone paging plan. 0=A, 1=B etc no I or Q
*22	Two tone precoded digits	up to 3	None	precoded digits preceding a two tone page
*23	Five Tone Plan	0-3	1	0 = EIA 1 = CCIR 2 = EEA 3 = ZVEI
*24	Five Tone tone period	0-3000	0040	ms tone period when paging
*25	Lead in period	0-3000	0500	ms from ptt to page send.
*26	Silence gap	0-3000	0045	ms gap between preamble tone and five tone page
*27	Preamble Tone	0-11	12	five tone preamble, 12 = Off
*28	Preamble Tone Length	0-3000	0000	five tone preamble duration
*29	Five Tone precoded digits	up to 5	None	digit prefixed to a five tone page
*30	Preferred line	0,1	0	Preferred out-dialing line. 0=line 1 1=line 2
*31	Call waiting tone	0,1	0	0 = no call waiting tone 1 = call waiting tone NOT IMPLEMENTED
*32	Radio Busy Indicator	0,1	0	0 = no answer when radio busy 1 = message when radio busy NOT IMPLEMENTED
*34	No Voice Prompts	0,1	0	0 = voice prompts to radio 1 = beeps to radio NOT IMPLEMENTED
*40	Radio Mode	1-4	1	(0=OFF) 1 = Simplex 2 = Tail Defeat 3 = Half Duplex 4 = Full Duplex
*42	Digital VOX Audio Delay	0-1000	0500	ms of audio delay after keying transmitter. (Prevent syllable loss from telephone party)
*43	PTT Off to COS Ignore (Repeater tail ignore)	0-3000	0420	ms ignore COS after PTT released. (ms from PTT off until COS recognized to prevent oscillation between Tx and Rx)
*44	Interconnect Enabled	0,1	0	TACT enabled NOT IMPLEMENTED
*45	Redial Busy	0,1	0	0 = terminate on busy number 1 = redial busy number NOT IMPLEMENTED

*46	Alarm Dialer	0,1	0	0 = no alarm dialer 1 = alarm dial on alarm input NOT IMPLEMENTED – refer to ‘Alarm Input’
*47	Remote On Off	0,1	0	1 = normal 2 = allow remote control on/off NOT IMPLEMENTED
*48	Unanswered call indicator	0,1	0	0 = normal 1 = allow caller to leave number NOT IMPLEMENTED
*49	Aux. Output Relay 1 mode	0,1	1	0 = disabled 1 = enabled
*50	Aux. Output Relay 2 mode	0,1	1	Ditto
*51	Alternate LEDS	0,1	0	0= normal 1 = alternate LED functions
*52	Error Number	0,1	0	0 = no error number 1 = error numbers NOT IMPLEMENTED
*53	Emergency Dial Delay	0-60	00	Seconds for emergency dial to occur NOT IMPLEMENTED
*54	Alarm Message to Air Repeat Timer	0-65	60	Seconds between alarm message to air 0 = Once to Air only
*55	PRVA allowed	0,1	0	0 = no PRVA 1 = PRVA NOT IMPLEMENTED
*56	DTMF Rx min on detect	0-255	040	ms of DTMF before detection
*57	DTMF Rx max off detect	0-255	040	ms gap in DTMF before absence
*58	COM baud rate	0-5	3	0 = 1200 1 = 2400 2 = 4800 3 = 9600 4 = 19200 5 = 38400
*59	COM1 baud rate	0-5	3	Ditto
*60	COM2 baud rate	0-5	3	Ditto
*61	Gain line 1 to line 2	000-030		dB Gain from line 1 to line 2. NOT USED.
*62	Gain line 2 to line 1	000-030		dB gain from line 2 to line 1. NOT USED
*63	PIN to make call	0,1	0	0 = no PIN 1 = PIN required to make call.
*64	PIN required to receive call in manual answer mode	0,1	0	0 = * to answer call 1 = PIN to answer call
*65	ID required after PIN entry	0,1	0	0 = PIN can immediately be followed by number or command 1 = user must wait after PIN for TACT ID
*66	Confirm manual number	0,1	0	0 = Dial after number entry 1 = Announce before dial NOT IMPLEMENTED
*67	Line VOX Hang time (VOX persistence)	0-1000	0100	PTT hold after line VOX de-activates and audio delay is empty
*68	COS detect filter	0-1000	0100	ms how long a drop out is allowed in the COS signal.
*69	Line VOX detect window (VOX sensitivity)	0-15	12	20ms × xx size of line VOX window. Increasing the window size increases sensitivity.
*70	Line VOX count (VOX attack time)	0-15	05	How many signal samples in line VOX Detect Window for VOX activation. Number must be less than VOX Detect Window. Decreasing the count quickens attack time.
*71	Analogue radio transmit gain (Line → Radio Analog Tx Gain)	0-42	15	dB analogue Tx gain to radio 21 = 0dB

*72	Analogue radio receive gain (Radio → Line Analog Rx Gain)	0-42	23	dB analogue Rx gain from radio. 21 = 0dB
*73	Digital gain radio to line (Radio → Line Digital Rx Gain)	0-99	46	dB digital Rx gain from radio 50 is 0dB
*74	Digital gain line to radio (Line → Radio Digital Tx Gain)	0-99	50	dB digital Tx gain to radio 50 is 0dB
*75	COS Sense	0,1	0	0 = COS active low 1 = COS active high
*76	Noise upper limit	0-255	100	qdB steps, sets upper limit for noise filters.
*77	COS Threshold	0 1-255	0 128	0 = digital (binary) input OR, Voltage reference relative to 5V. (128 = centre of COS swing 0 → 5V)
*78	No Rx from radio disconnect timer	1-255	060	ms How soon radio must transmit to line for connection to line to remain.
*79	Radio VOX detect window	0-15	12	20ms × xx size of radio VOX window.
*80	Radio VOX count	0-15	5	How many signal samples in radio VOX Detect Window for VOX detection. Must be less than VOX Detect Window.
*81	Radio Absolute signal level detect (Radio VOX minimum activate level)	0-255	080	qdB. Minimum detect threshold for Radio. Bigger is less sensitive
*90	Watchdog Timer	0-255	060	M – how often does TACT ask for a response from the Lone Worker
*91	Response & Reminder Timer	0-255	060	s – how long does Lone Worker have to respond.
*#	Save and exit	-	-	Save changes and exit

ms = milliseconds

s = seconds

M = minutes

dB = decibels

qdB = quarter decibels

EPROM VERSION NUMBER

The firmware version reveals the vintage and features available with your TACT.

1. Press *48# on the TACT keypad to read back the EPROM version number.

CONNECTION DIAGRAM

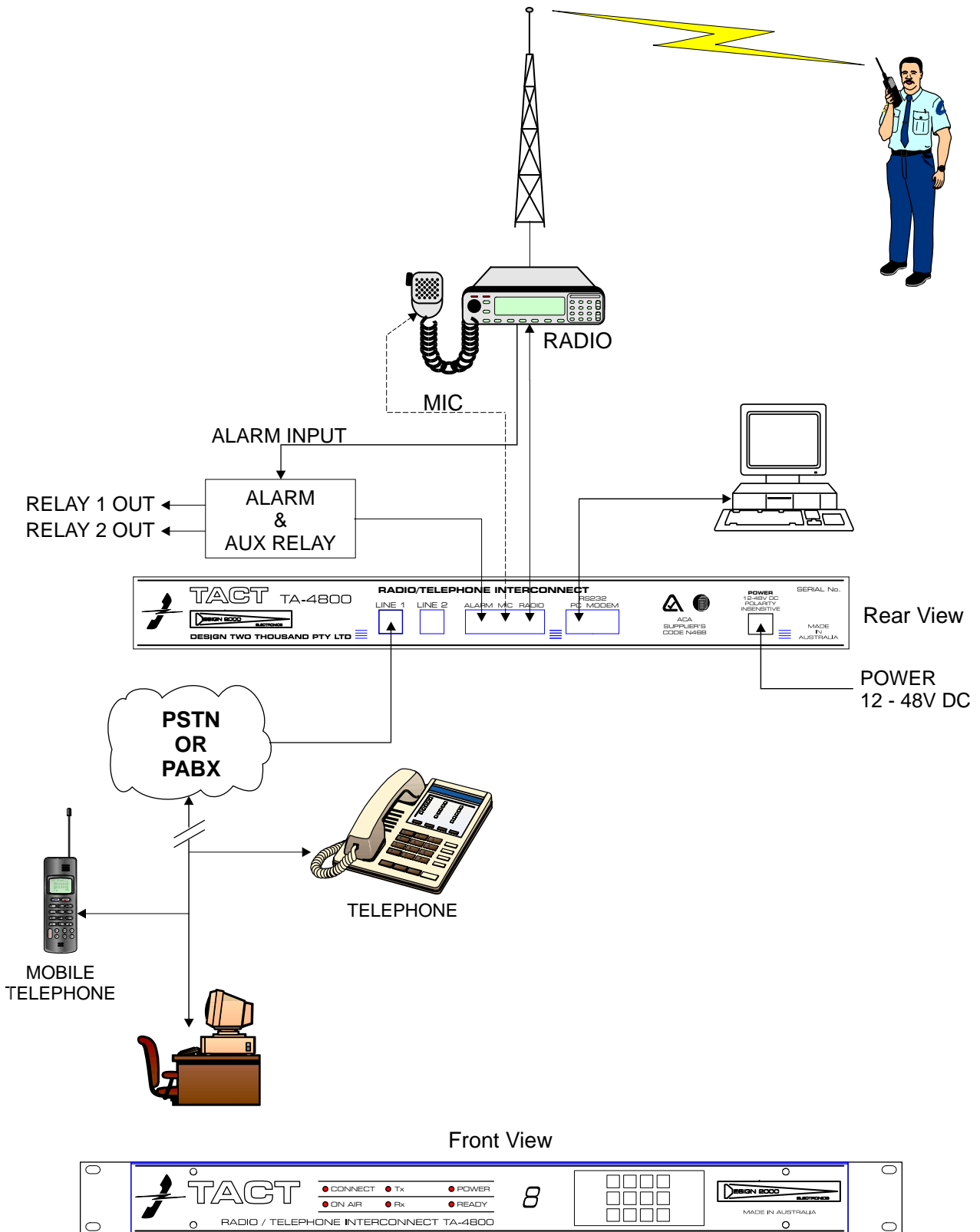

CONNECTIONS

RADIO

PIN	DESCRIPTION
1	PTT Common
2	PTT Normally Open
3	MAP 27 (Digital) Out
4	COS Indication from Radio
5	MAP 27 (Digital) In
6	Signal Ground (Return) (OV)
7	Audio Out from TACT to Radio (Tx)
8	Audio In to TACT from Radio (Rx)

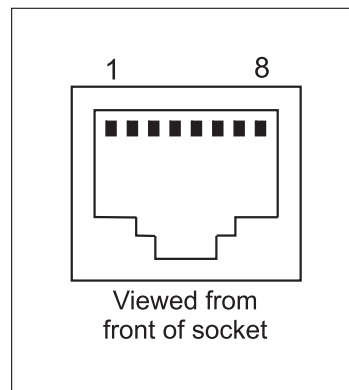

TELEPHONE

LINE 1

PIN	DESCRIPTION
1	
2	
3	Ring (Lb)
4	Tip (La)
5	
6	

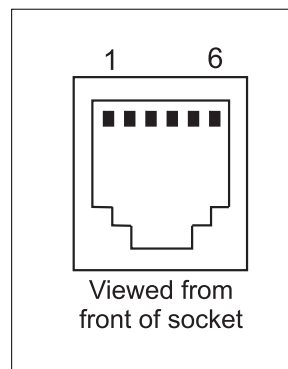

LINE 2

PIN	DESCRIPTION
1	
2	
3	Ring (Lb)
4	Tip (La)
5	
6	

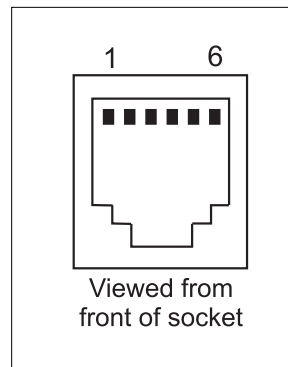

ALARM INPUT & AUXILIARY OUTPUT RELAYS

PIN	DESCRIPTION
1	Relay 1 Normally Open
2	Relay 1 Common
3	Relay 1 Normally Closed
4	Alarm In
5	Ground
6	Relay 2 Normally Open
7	Relay 2 Common
8	Relay 2 Normally Closed

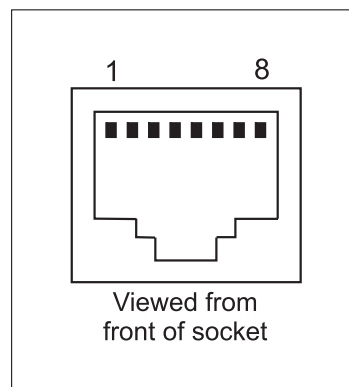

PC RS232 (Configured as DCE)

PIN	DESCRIPTION
1	CD (Common to Modem)
2	RI (Common to Modem)
3	RXD (Data received by PC)
4	DTR (Common to Modem)
5	TXD (Data Transmitted by PC)
6	Ground
7	RTS (Common to Modem)
8	CTS (Common to Modem)

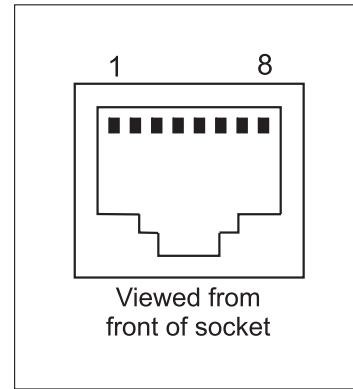

MODEM RS232 (Configured as DCE)

PIN	DESCRIPTION
1	CD (Common to PC)
2	RI (Common to PC)
3	RXD (Data received by Modem)
4	DTR (Common to PC)
5	TXD (Data Transmitted by Modem)
6	Ground
7	RTS (Common to PC)
8	CTS (Common to PC)

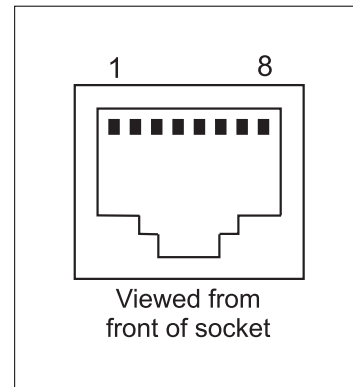

POWER

PIN	DESCRIPTION
1	12 → 48 Vdc polarity insensitive
2	Power return

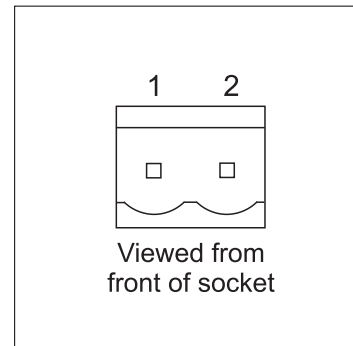

AUDIO LEVEL ADJUSTMENTS

Please Note: The TA-4800 Tx and Rx audio levels are factory preset to suit most popular radios. Therefore field adjustment is generally not required, and we recommend that you try using TACT before attempting the following set up procedures.

AUDIO OUTPUT TO RADIO (Tx LEVEL) (SETTING THE MODULATION LEVEL)

This procedure is to adjust the Tx audio level from the telephone line to the radio.

The audio output from TACT to the radio is found on Pin 7 of the 'RADIO' connector. It can be connected to the radio's mic input or similar point. The TACT keypad is used to adjust the audio level to radio for correct modulation. If using microphone sensitivity input, a 10:1 resistive voltage divider across the mic input circuit is recommended.

The Tx level setting procedure is as follows:

1. Press *97# on the TACT keypad. TACT will respond by transmitting an 820 Hz test tone via the base radio to the mobile for 120 seconds. With an appropriate test set connected to the base radio transmitter output, repeatedly press * to increase or # to decrease the test tone (you can also press a digit 1 → 9 to select an absolute level and then fine tune with the * and # keys) until the test set indicates the correct modulation level. (Refer to the radio manufacturer's documentation and appropriate regulations for relevant specifications. For FM sets the signal should deviate the RF carrier 2.5kHz on systems with 25kHz channel spacing or 1.25kHz on systems with 12.5kHz channel spacing).
 - If a suitable test set is not available, use an ac Volt meter to monitor the input to the radio and repeatedly press * to increase or # to decrease the signal level to match the input specifications of the radio. For example, a radio may require 100 mV at its input. (You can also adjust the level by ear. Listen to the test tone on a receiving mobile, and using the procedure described above, adjust the level until it sounds clear and free of distortion).
2. Press 0 to save and exit. TACT reads back a two digit value for Option *71 in the system configuration options.

AUDIO INPUT FROM RADIO (Rx LEVEL)

This procedure is to adjust the Rx audio level from the radio to the telephone line.

Audio output from the radio (300 → 500 mV p-p recommended) is fed into TACT via Pin 8 of the 'RADIO' connector. As a last resort, the radio speaker output may be used as the audio source. The input impedance of the TACT radio receive audio port is normally 4k7 Ohms or 600 Ohms nominal with LK15 linked.

To meet ACA specifications, the DTMF audio level from TACT to line should not exceed -6dBm. The radio being used should be adjusted so that -6dBm to line is not exceeded.

The easiest method to calibrate the Rx level to line without expensive or additional equipment is as follows:

1. Make sure that the level from radio to TACT is less than 1V rms.
2. Connect the telephone line to Line 1 OR apply a dc loop current to line 1, similar to a 'Telco' line (600 ohms). Place a dB or ac Volt meter across the line.
3. Press *98# on the TACT keypad.
4. Press and hold 5 on a mobile radio keypad to provide a continuous tone from the radio to the TACT.
5. Repeatedly press (on the TACT keypad) * to increase or # to decrease the signal (you can also press a digit 1 → 9 to select an absolute level and then fine tune with the * and # keys) so that the output level is around -6dBm or 0.388 V rms).
 - You can also observe the TACT display and adjust the level until the display just changes from 6 to 7.
6. Press 0 to save and exit. TACT reads back a two digit value for Option *72 in the system configuration options.

PTT AND COS

PRESS TO TALK (PTT) OUTPUT TO RADIO

Description

A relay is provided to apply press to talk (PTT) to the radio when the transmitter is to be keyed. Keying the transmitter also allows TACT to transmit audio from the telephone to the radio field. Normally a radio will require a contact closure to ground to activate its PTT (or key its transmitter).

Connection

'PTT Common' is on Pin 1 of the 'RADIO' connector and 'PTT Normally Open' is on Pin 2 of the 'RADIO' connector. The radio's Ground or 0V should be connected to Pin 1 and the radio's PTT input should be connected to Pin 2. If the radio requires a voltage input to activate its PTT then a suitable external voltage should be connected in series with Pin 2.

CARRIER OPERATED SQUELCH (COS) INPUT FROM RADIO

Description and Programming

TACT requires a COS signal from the base radio or repeater when it is receiving a transmission from a mobile. It may take the form of contact closure or a voltage.

TACT must be programmed accordingly:

*6703#		Range	Default	
*75	COS Sense	0,1	0	0 = COS active low 1 = COS active high
*77	COS Threshold	0	0	0 = digital (binary) input OR:
		1-255	128	Voltage reference relative to 5V. (128 = centre of COS swing 0 → 5V)
*#				

Normally, TACT is supplied configured for a contact closure and supplies +5V via 100K to the radio. 'COS Threshold' must then be set to 0 to denote a binary input, and the 'COS Sense' set to 0 if a contact closure to ground denotes a valid COS condition. 'COS Sense' is set to 1 if a valid COS is denoted by an open condition.

Should the radio present a voltage to indicate the COS condition, the 'COS Threshold' must be set to a number in the range 1 to 255 inclusive. 1 represents near 0V and 255 represents +5V. For example, if the radio presents a voltage in the range +0.5V to +3.0V, then the 'COS Threshold' would be set to $\{[(3.0V - 0.5V)/2 + 0.5V]/5V\} \times 255 = 89$, ie. in the middle of the input voltage range. Note that if either limit is outside the range 0 → 5V, for example -5V to +10V, then while the input is protected against modest voltage excess, only the portion from 0 → 5V is recognised and in such an instance the 'COS Threshold' would be set to 128, ie. half the sensing range. 'COS Sense' must then be set to 1 if the upper voltage represents valid COS or set to 0 if the lower voltage represents valid COS. Additionally, the voltage source in the radio must be capable of sinking the small current presented by the COS input, ie. about 50 micro Amps. If this is not so, then resistor R104 must be removed from TACT and re-installed into position R106.

Connection

The COS output from the radio is connected to Pin 4 of the 'RADIO' connector and is sensed relative to ground or 0V with Pin 6 of the 'RADIO' connector connected to the signal ground (0V) of the radio.

SUMMARY OF USER CODES

CODE	FACILITY	
123	TACT Watchdog ON	
321	TACT Watchdog OFF	
5	Reset Alarm (from phone)	
*6703#	Access to System Timers	
*90 mmm	Adjust Watchdog Timer to mmm minutes	
*91 sss	Adjust Response Timer to sss seconds	
*#	Save changes	
* 81 nnnnnnnn #	Alarm dial number one	
* 82 nnnnnnnn #	Alarm dial number two	
* 83 nnnnnnnn #	Alarm dial number three	
* 84 nnnnnnnn #	Alarm dial number four	
* 8n 0 #	Erase alarm dial number	
5	Stop dialer (from telephone)	
* 07 0 #	Reset auxiliary relay one	Radio or Phone
* 07 1 #	Operate auxiliary relay one	Radio or Phone
* 07 #	Interrogate relay one state	Radio or Phone
* 08 0 #	Reset auxiliary relay two	Radio or Phone
* 08 1 #	Operate auxiliary relay two	Radio or Phone
* 08 #	Interrogate relay two state	Radio or Phone
* 67 03 #	System configuration access	
* nn	Option number	
n...	Entry	
#	Scroll	
* *	Abandon	
* #	Store & end	
* 48 #	EPROM version number	

SPECIFICATIONS

SPECIFICATIONS

Enclosure		1U high, 19" rack mount.
Finish		Dulux metallic charcoal powder coat.
Power Requirement		12 → 48 Vdc nominal, polarity and ground insensitive.
Power Consumption		65 mA @ 48 V 135 mA @ 24 V 300 mA @ 12 V ie. 3.2 W nominal @ 48V
Initial Start Up Current		300 mA for 40 ms @ 48 V 500 mA for 50 ms @ 24 V 750 mA for 90 ms @ 12 V
Operating Temperature Range		-10 → +70 ° C.
Storage Temperature Range		-20 → 80 ° C ambient.
Humidity, Storage and Operating		To 98% non condensing.
Mean Time Between Failure:		> 20 years.
TACT Radio Interface	IN	50K Ohm input impedance. Strappable 600 Ohm termination.
	OUT	600 Ohm output impedance.
Input level		-30 → +10 dBm adjustable (-13.5 dBm nom.).
Output level		-30 → +10 dBm adjustable. (-13.5 dBm nom.).
Frequency range		300 Hz → 5 kHz.
COS detect		High impedance input, floating to +5V, grounded by radio to indicate COS.
PTT		Relay contact, switching to ground for PTT activation.
Telephone Line Interface		Standard two wire analogue ring in/loop out.
Ringer Equivalent Number (REN)		0.5.
Ring Detect		≥ 10V RMS @ 13-55 Hz (25 Hz nominal), ≥100 ms.
Answer Delay		100 ms.
In-band Signalling		<u>D</u> ual <u>T</u> one <u>M</u> ulti <u>F</u> requency (DTMF).
DTMF Dialler		70 ms on/off, -10dBm.
DTMF Receiver		-40 → 0 dBm sensitivity.
5 Tone Paging Protocol		CCIR 40 ms.
Keypad		12 push button 4 x 3 numeric silicone membrane keypad.
Displays		7 segment numeric readout, 6 x status LEDs.
RS232 Port		9600 baud, N81 format.
Telephone Service Tone detection		-30 dBm sensitivity, automatic cadence detection.
ACA Supplier Code Number		N468.
Warranty		Two years
Firmware Storage Medium		EPROM
System Number		V99305.04 (V4869.04 or later) – allows standard TACT operation also.
Speech Number		V99306

TACT MODEL TA-4800

Designed and Manufactured By:

design2000

DESIGN TWO THOUSAND PTY LTD

9-11 ROSE STREET

UPPER FERNTREE GULLY

MELBOURNE 3156

Telephone: (03) 9758 5933 Facsimile: (03) 9758 5560
E-mail: gen@design2000.com.au Web Site: www.design2000.com.au

DESIGN TWO THOUSAND PTY LTD IS CERTIFIED TO ISO9001



ACMA SUPPLIER'S CODE: N468

AUTHOR: PETER ZEUG
DESIGN TWO THOUSAND PTY LTD

*** END OF DOCUMENT G/00123C ***